



Module LLE G2 24mm 1250lm SNC

Modules LLE ESSENCE

Product description

- Optimal solution for linear and panel lights where cost is main priority, together with the new LC Ip SNC and ADV LED Driver provides best system efficiency
- SELV module – the single module has a forward voltage < 60 V
- Terminals – 2 variants:
 - 2 terminals for serial wiring
 - 4 terminals for parallel, serial or robot wiring
- Typ. luminous flux 1,250 and 2,400 lm
- Efficiency of the module up to 171 lm/W
- High colour rendering index CRI > 80
- Small colour tolerance MacAdam 4[®]
- Colour temperatures 3,000, 4,000 and 6,500 K
- Module dimension 24 x 280 mm and 24 x 560 mm (ZHAGA compliant)
- Perfectly uniform light, even if several LED modules are used together in a line
- Push terminals for quick and simple wiring of LED module to LED module
- Simple installation (e.g. ACL push fix)
- Long life-time up to 50,000 hours
- 5-year guarantee



LLE G2 24x280mm 1250lm SNC



LLE G2 24x560mm 2400lm SNC



Standards, page 7

Colour temperatures and tolerances, page 12

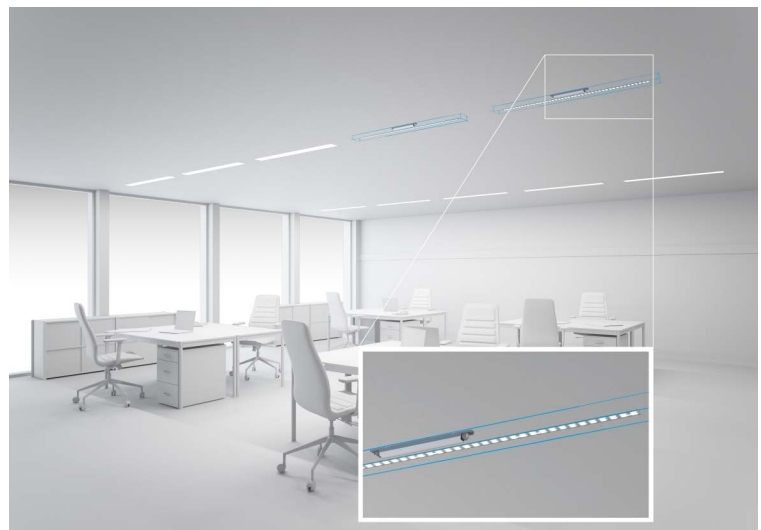



Module LLE G2 24mm 1250lm SNC

Modules LLE ESSENCE

Technical data

Beam characteristic	120°
Ambient temperature range	-40 ... +60 °C
tp rated	65 °C
tc	85 °C
Irated	350 mA
I _{max}	540 mA
Max. permissible LF current ripple	540 mA
Max. permissible peak current	1,200 mA / max. 10 ms
Max. working voltage for insulation [®]	335 V
Insulation test voltage	1,67 kV
CTI of the printed circuit board	≥ 600
ESD classification	severity level 4
Risk group (IEC 62471:2008) at I _{max}	RG2 (E _{thr} = 570 lx, RG1 at d ≥ 105 cm)
Risk group (IEC 62471:2008) at I = 490 mA	RG1
Classification acc. to IEC 62031	Built-in
Type of protection	IP00

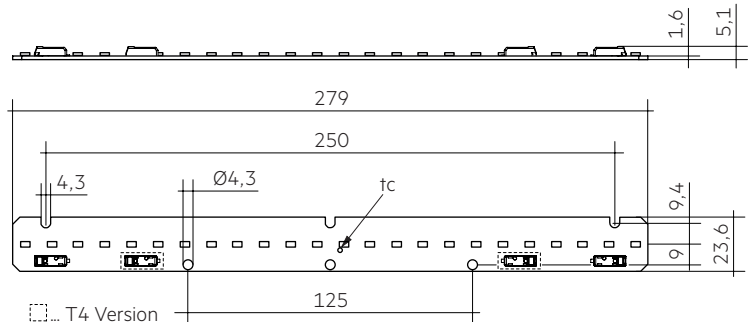

LLE G2 24x280mm 1250lm SNC

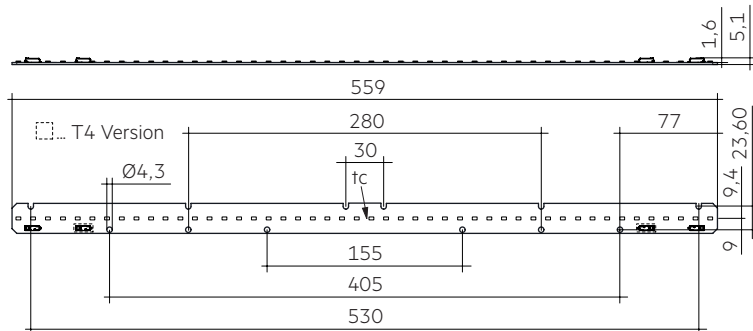

LLE G2 24x560mm 2400lm SNC

Ordering data

Type	Article number	Colour temperature	Packaging carton	Weight per pc.
LLE 24mm ESSENCE 2 terminals (2T) for serial wiring				
LLE G2 24x280mm 1250lm 830 2T SNC	28002006	3,000 K	300 pc(s).	0,022 kg
LLE G2 24x280mm 1250lm 840 2T SNC	28002007	4,000 K	300 pc(s).	0,022 kg
LLE G2 24x280mm 1250lm 865 2T SNC	28002008	6,500 K	300 pc(s).	0,022 kg
LLE G2 24x560mm 2400lm 830 2T SNC	28002009	3,000 K	240 pc(s).	0,043 kg
LLE G2 24x560mm 2400lm 840 2T SNC	28002010	4,000 K	240 pc(s).	0,043 kg
LLE G2 24x560mm 2400lm 865 2T SNC	28002011	6,500 K	240 pc(s).	0,043 kg
LLE 24mm ESSENCE 4 terminals (4T) for SELV				
LLE G2 24x280mm 1250lm 830 4T SNC	28002018	3,000 K	300 pc(s).	0,022 kg
LLE G2 24x280mm 1250lm 840 4T SNC	28002019	4,000 K	300 pc(s).	0,022 kg
LLE G2 24x280mm 1250lm 865 4T SNC	28002020	6,500 K	300 pc(s).	0,022 kg
LLE G2 24x560mm 2400lm 830 4T SNC	28002021	3,000 K	240 pc(s).	0,043 kg
LLE G2 24x560mm 2400lm 840 4T SNC	28002022	4,000 K	240 pc(s).	0,043 kg
LLE G2 24x560mm 2400lm 865 4T SNC	28002023	6,500 K	240 pc(s).	0,043 kg

Specific technical data

Type [®]	Photo-metric code	Typ. luminous flux at tp = 25 °C [®]	Typ. luminous flux at tp = 65 °C [®]	Typ. forward current	Min. forward voltage at tp = 65 °C	Max. forward voltage at tp = 25 °C	Typ. power consumption at tp = 65 °C [®]	Efficacy of the module at tp = 25 °C	Efficacy of the module at tp = 65 °C	Efficacy of the system at tp = 65 °C	Colour rendering index CRI
Operating mode HE at 200 mA											
LLE G2 24x280mm 1250lm 830 SNC	830/469	740 lm	690 lm	200 mA	20.6 V	24.3 V	4.5 W	159 lm/W	151 lm/W	136 lm/W	> 80
LLE G2 24x280mm 1250lm 840 SNC	840/469	790 lm	740 lm	200 mA	20.6 V	24.3 V	4.5 W	171 lm/W	163 lm/W	147 lm/W	> 80
LLE G2 24x280mm 1250lm 865 SNC	865/469	790 lm	720 lm	200 mA	20.6 V	24.3 V	4.5 W	169 lm/W	159 lm/W	143 lm/W	> 80
LLE G2 24x560mm 2400lm 830 SNC	830/469	1,480 lm	1,370 lm	200 mA	41.2 V	48.6 V	9.1 W	159 lm/W	151 lm/W	136 lm/W	> 80
LLE G2 24x560mm 2400lm 840 SNC	840/469	1,590 lm	1,480 lm	200 mA	41.2 V	48.6 V	9.1 W	171 lm/W	163 lm/W	147 lm/W	> 80
LLE G2 24x560mm 2400lm 865 SNC	865/469	1,570 lm	1,440 lm	200 mA	41.2 V	48.6 V	9.1 W	169 lm/W	159 lm/W	143 lm/W	> 80
Operating mode HE at 250 mA											
LLE G2 24x280mm 1250lm 830 SNC	830/469	910 lm	840 lm	250 mA	21.1 V	24.8 V	5.8 W	153 lm/W	145 lm/W	131 lm/W	> 80
LLE G2 24x280mm 1250lm 840 SNC	840/469	970 lm	910 lm	250 mA	21.1 V	24.8 V	5.8 W	164 lm/W	156 lm/W	140 lm/W	> 80
LLE G2 24x280mm 1250lm 865 SNC	865/469	960 lm	890 lm	250 mA	21.1 V	24.8 V	5.8 W	163 lm/W	153 lm/W	138 lm/W	> 80
LLE G2 24x560mm 2400lm 830 SNC	830/469	1,810 lm	1,680 lm	250 mA	42.3 V	49.7 V	11.6 W	153 lm/W	145 lm/W	131 lm/W	> 80
LLE G2 24x560mm 2400lm 840 SNC	840/469	1,950 lm	1,810 lm	250 mA	42.3 V	49.7 V	11.6 W	164 lm/W	156 lm/W	140 lm/W	> 80
LLE G2 24x560mm 2400lm 865 SNC	865/469	1,930 lm	1,770 lm	250 mA	42.3 V	49.7 V	11.6 W	163 lm/W	153 lm/W	138 lm/W	> 80
Operating mode NM at 300 mA											
LLE G2 24x280mm 1250lm 830 SNC	830/469	1,070 lm	990 lm	300 mA	21.6 V	25.3 V	7.1 W	147 lm/W	140 lm/W	126 lm/W	> 80
LLE G2 24x280mm 1250lm 840 SNC	840/469	1,150 lm	1,070 lm	300 mA	21.6 V	25.3 V	7.1 W	158 lm/W	150 lm/W	135 lm/W	> 80
LLE G2 24x280mm 1250lm 865 SNC	865/469	1,140 lm	1,050 lm	300 mA	21.6 V	25.3 V	7.1 W	157 lm/W	147 lm/W	132 lm/W	> 80
LLE G2 24x560mm 2400lm 830 SNC	830/469	2,140 lm	1,990 lm	300 mA	43.3 V	50.6 V	14.2 W	147 lm/W	140 lm/W	126 lm/W	> 80
LLE G2 24x560mm 2400lm 840 SNC	840/469	2,290 lm	2,130 lm	300 mA	43.3 V	50.6 V	14.2 W	158 lm/W	150 lm/W	135 lm/W	> 80
LLE G2 24x560mm 2400lm 865 SNC	865/469	2,270 lm	2,090 lm	300 mA	43.3 V	50.6 V	14.2 W	157 lm/W	147 lm/W	132 lm/W	> 80
Operating mode NM at 350 mA											
LLE G2 24x280mm 1250lm 830 SNC	830/469	1,220 lm	1,140 lm	350 mA	22.1 V	25.8 V	8.5 W	142 lm/W	135 lm/W	122 lm/W	> 80
LLE G2 24x280mm 1250lm 840 SNC	840/469	1,320 lm	1,230 lm	350 mA	22.1 V	25.8 V	8.5 W	152 lm/W	145 lm/W	131 lm/W	> 80
LLE G2 24x280mm 1250lm 865 SNC	865/469	1,300 lm	1,200 lm	350 mA	22.1 V	25.8 V	8.5 W	151 lm/W	142 lm/W	128 lm/W	> 80
LLE G2 24x560mm 2400lm 830 SNC	830/469	2,450 lm	2,280 lm	350 mA	44.2 V	51.6 V	16.9 W	142 lm/W	135 lm/W	122 lm/W	> 80
LLE G2 24x560mm 2400lm 840 SNC	840/469	2,630 lm	2,450 lm	350 mA	44.2 V	51.6 V	16.9 W	152 lm/W	145 lm/W	131 lm/W	> 80
LLE G2 24x560mm 2400lm 865 SNC	865/469	2,600 lm	2,400 lm	350 mA	44.2 V	51.6 V	16.9 W	151 lm/W	142 lm/W	128 lm/W	> 80
Operating mode HO at 400 mA											
LLE G2 24x280mm 1250lm 830 SNC	830/469	1,370 lm	1,270 lm	400 mA	22.6 V	26.3 V	9.9 W	136 lm/W	129 lm/W	116 lm/W	> 80
LLE G2 24x280mm 1250lm 840 SNC	840/469	1,470 lm	1,370 lm	400 mA	22.6 V	26.3 V	9.9 W	146 lm/W	138 lm/W	124 lm/W	> 80
LLE G2 24x280mm 1250lm 865 SNC	865/469	1,450 lm	1,340 lm	400 mA	22.6 V	26.3 V	9.9 W	145 lm/W	136 lm/W	122 lm/W	> 80
LLE G2 24x560mm 2400lm 830 SNC	830/469	2,730 lm	2,540 lm	400 mA	45.2 V	52.5 V	19.7 W	136 lm/W	129 lm/W	116 lm/W	> 80
LLE G2 24x560mm 2400lm 840 SNC	840/469	2,940 lm	2,730 lm	400 mA	45.2 V	52.5 V	19.7 W	146 lm/W	138 lm/W	124 lm/W	> 80
LLE G2 24x560mm 2400lm 865 SNC	865/469	2,910 lm	2,670 lm	400 mA	45.2 V	52.5 V	19.7 W	145 lm/W	136 lm/W	122 lm/W	> 80
Operating mode HO at 450 mA											
LLE G2 24x280mm 1250lm 830 SNC	830/469	1,510 lm	1,410 lm	450 mA	23.5 V	27.2 V	12.8 W	131 lm/W	125 lm/W	113 lm/W	> 80
LLE G2 24x280mm 1250lm 840 SNC	840/469	1,630 lm	1,510 lm	450 mA	23.5 V	27.2 V	12.8 W	141 lm/W	134 lm/W	121 lm/W	> 80
LLE G2 24x280mm 1250lm 865 SNC	865/469	1,610 lm	1,480 lm	450 mA	23.5 V	27.2 V	12.8 W	140 lm/W	131 lm/W	118 lm/W	> 80
LLE G2 24x560mm 2400lm 830 SNC	830/469	3,030 lm	2,810 lm	450 mA	46.1 V	53.4 V	22.6 W	131 lm/W	125 lm/W	113 lm/W	> 80
LLE G2 24x560mm 2400lm 840 SNC	840/469	3,250 lm	3,020 lm	450 mA	46.1 V	53.4 V	22.6 W	141 lm/W	134 lm/W	121 lm/W	> 80
LLE G2 24x560mm 2400lm 865 SNC	865/469	3,220 lm	2,960 lm	450 mA	46.1 V	53.4 V	22.6 W	140 lm/W	131 lm/W	118 lm/W	> 80

[®] Integral measurement over the complete module.

[®] If mounted with M4 screws and plastic washers.

[®] HE ... high efficiency, NM ... nominal mode, HO ... high output.

[®] Tolerance range for optical and electrical data: ±10 %.

Product description

- LINEAR COVER for LLE 24
- Protection against direct touch for non-SELV applications
- Fast snap on mounting on to LLE 24 with clips or plastic washers
- High transmission: transparent 94 %, semi-transparent 87 %, diffuse 76 %
- Made of PMMA
- Tolerances: ± 1 mm for 597 mm length (ends finished),
+ 20 mm for 1,200 / 1,500 / 1,600 / 1,800 mm length (ends raw)

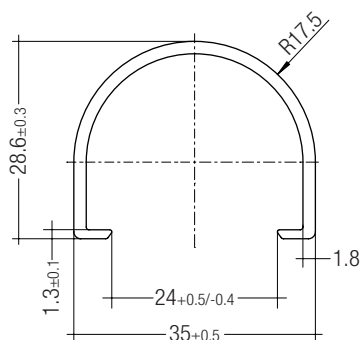
**Ordering data**

Type	Article number	Colour	Length	Packaging carton	Weight per pc.
LINEAR COVER SY Transparent 1600mm	28000338	Transparent	1,600 mm	12 pc(s).	0.272 kg
LINEAR COVER SY Frosted 1800mm	28000437	Semi-transparent	1,800 mm	12 pc(s).	0.308 kg
LINEAR COVER SY Frosted 1600mm	28000339	Semi-transparent	1,600 mm	12 pc(s).	0.272 kg
LINEAR COVER SY Frosted 1500mm	28000435	Semi-transparent	1,500 mm	12 pc(s).	0.244 kg
LINEAR COVER SY Frosted 1200mm	28000422	Semi-transparent	1,200 mm	12 pc(s).	0.205 kg
LINEAR COVER SY Frosted 597mm	28000340	Semi-transparent	597 mm	12 pc(s).	0.102 kg
LINEAR COVER SY Diffuse 1800mm	28000438	Diffuse	1,800 mm	12 pc(s).	0.308 kg
LINEAR COVER SY Diffuse 1600mm	28000341	Diffuse	1,600 mm	12 pc(s).	0.272 kg
LINEAR COVER SY Diffuse 1500mm	28000436	Diffuse	1,500 mm	12 pc(s).	0.257 kg
LINEAR COVER SY Diffuse 1200mm	28000434	Diffuse	1,200 mm	12 pc(s).	0.205 kg
LINEAR COVER SY Diffuse 597mm	28000342	Diffuse	597 mm	12 pc(s).	0.102 kg

ACL ENDCAP LLE24 PUSH-FIX

Product description

- ENDCAP for LLE 24
- Fast snap on mounting (sheet thickness 0.5 – 1.0 mm), for drilling hole 4 mm
- Made of Polycarbonat

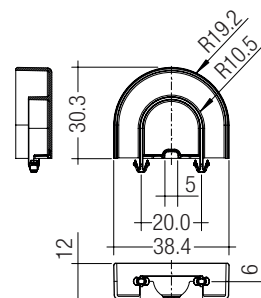

Ordering data

Type	Article number	Colour	Packaging carton	Weight per pc.
ACL ENDCAP LLE24 PUSH-FIX	28001037	White	480 pc(s).	0.003 kg

LINEAR LENS

Product description

- Linear lens for LLE 24
- Available in 60° and 90° light distribution
- Protection against direct touch for non-SELV applications
- Fast snap on mounting on to LLE 24 with clips or plastic washers
- High transmission: semi-transparent 97 %
- Linear lense made of PMMA
- Tolerances: ± 20 mm for 1,600 mm length (ends raw)

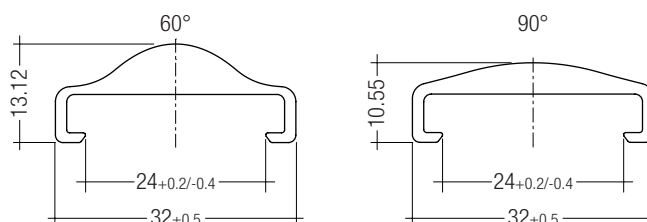

Ordering data

Type	Article number	Colour	Length	Packaging carton	Weight per pc.
ACL LINEAR LENS 24x1200mm 60°	28001428	Semi-transparent	1,200 mm	21 pc(s).	0.196 kg
ACL LINEAR LENS 24x1200mm 90°	28001429	Semi-transparent	1,200 mm	21 pc(s).	0.165 kg
ACL LINEAR LENS 24x1600mm 60°	28000953	Semi-transparent	1,600 mm	21 pc(s).	0.261 kg
ACL LINEAR LENS 24x1600mm 90°	28000955	Semi-transparent	1,600 mm	21 pc(s).	0.221 kg

CLIP 4.3mm

Product description

- Clip for fixation of LED modules with 4.3 mm holes
- Fast snap on mounting (sheet thickness 0.5 – 1.0 mm)
- For drilling hole 4 mm
- Clip made of Polycarbonat

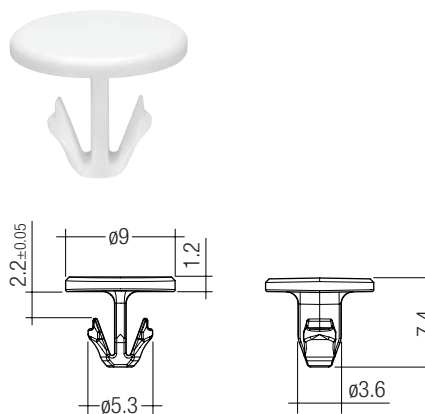

Ordering data

Type	Article number	Colour	Packaging bag [®]	Weight per pc.
ACL CLIP 4.3mm PUSH-FIX	28001036	White	500 pc(s).	0.001 kg

[®] Minimum sales quantity 500 pcs.

BRIDGE LLE24/40

Product description

- Enables the fixation of 24 mm wide Tridonic LED modules to fixtures made for 40 mm wide modules
- Ideal for extruded aluminium gear trays made for 40 mm modules with pre-alignment knobs
- Clip-on for LINEAR COVER and LINEAR LENS[®]
- For LLE 24 with 280 mm module minimum 2 bridges required
- For LLE 24 with 560 mm module minimum 3 bridges required
- Fixation via M3 or M4 countersunk screw, max. tightening torque 0.5 Nm
- BRIDGE made of white polycarbonate

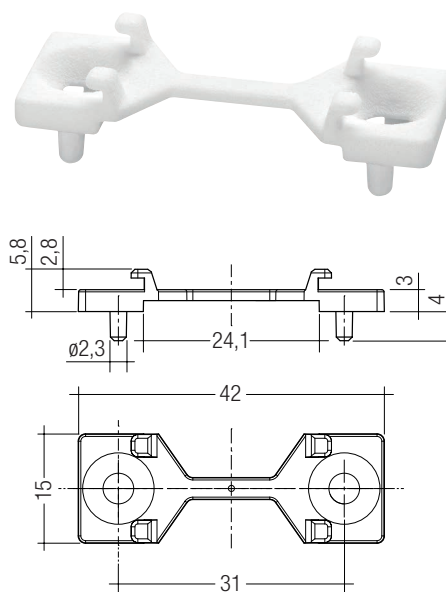

Ordering data

Type	Article number	Colour	Packaging carton [®]	Weight per pc.
ACL BRIDGE LLE24/40 SCREW-FIX	28001205	White	600 Stk.	0.001 kg

[®] Minimum sales quantity 600 pcs.

[®] Beam characteristics will change due to the elevated fixation (see photometric files for details).

1. Standards

IEC 62031
IEC 62471
IEC 62778
IEC 62717

1.1 Photometric code

Key for photometric code, e. g. 830 / 349

1 st digit	2 nd + 3 rd digit	4 th digit	5 th digit	6 th digit		
Code	Colour temperature in Kelvin x 100	McAdam initial	McAdam after 25% of the life-time (max.6000h)	Luminous flux after 25% of the life-time (max.6000h)		
CRI				Code	Luminous flux	
7				70 – 79	7	≥ 70 %
8				80 – 89	8	≥ 80 %
9	≥90	9	≥ 90 %			

1.2 Energy classification

Typ	Energieklassifizierung
LLE G2 24mm SNC	A++

2. Thermal details

2.1 tc point, ambient temperature and life-time

The temperature at tp reference point is crucial for the light output and life-time of a LED product.

For LLE a tp temperature of 65 °C has to be complied in order to achieve an optimum between heat sink requirements, light output and life-time.

Compliance with the maximum permissible reference temperature at the tc point must be checked under operating conditions in a thermally stable state. The maximum value must be determined under worst-case conditions for the relevant application.

The tc and tp temperature of LED modules from Tridonic are measured at the same reference point.

2.2 Storage and humidity

Storage temperature	-40 ... +100 °C
---------------------	-----------------

Operation only in non condensing environment.

Humidity during processing of the module should be between 30 to 70 %.

2.3 Thermal design and heat sink

The rated life of LED products depends to a large extent on the temperature. If the permissible temperature limits are exceeded, the life of the LLE will be greatly reduced or the LLE may be destroyed.

2.4 Heat sink values

LLE G2 24x280mm 1250lm 8xx SNC

ta	tp	Forward current	R _{th, hs-a}	Cooling area
25 °C	65 °C	250 mA		self cooling
25 °C	65 °C	300 mA	9.85 K/W	68 cm ²
25 °C	65 °C	350 mA	7.99 K/W	83 cm ²
25 °C	65 °C	400 mA	6.67 K/W	100 cm ²
25 °C	65 °C	450 mA	5.69 K/W	117 cm ²
35 °C	65 °C	250 mA	9.31 K/W	72 cm ²
35 °C	65 °C	300 mA	7.39 K/W	68 cm ²
35 °C	65 °C	350 mA	5.99 K/W	111 cm ²
35 °C	65 °C	400 mA	5.00 K/W	133 cm ²
35 °C	65 °C	450 mA	4.26 K/W	156 cm ²
40 °C	65 °C	250 mA	7.76 K/W	86 cm ²
40 °C	65 °C	300 mA	6.15 K/W	108 cm ²
40 °C	65 °C	350 mA	4.99 K/W	134 cm ²
40 °C	65 °C	400 mA	4.17 K/W	160 cm ²
40 °C	65 °C	450 mA	3.55 K/W	188 cm ²
45 °C	65 °C	250 mA	8.38 K/W	80 cm ²
45 °C	65 °C	300 mA	4.92 K/W	135 cm ²
45 °C	65 °C	350 mA	3.99 K/W	167 cm ²
45 °C	65 °C	400 mA	3.33 K/W	200 cm ²
45 °C	65 °C	450 mA	2.84 K/W	235 cm ²
50 °C	65 °C	250 mA	6.28 K/W	106 cm ²
50 °C	65 °C	300 mA	3.69 K/W	181 cm ²
50 °C	65 °C	350 mA	2.99 K/W	223 cm ²
50 °C	65 °C	400 mA	2.50 K/W	267 cm ²
50 °C	65 °C	450 mA	2.13 K/W	313 cm ²
55 °C	65 °C	250 mA	4.18 K/W	159 cm ²
55 °C	65 °C	300 mA	2.46 K/W	271 cm ²
55 °C	65 °C	350 mA	1.99 K/W	334 cm ²
55 °C	65 °C	400 mA	1.66 K/W	401 cm ²
55 °C	65 °C	450 mA	1.42 K/W	470 cm ²
60 °C	65 °C	250 mA	2.09 K/W	319 cm ²
60 °C	65 °C	300 mA	1.23 K/W	544 cm ²
60 °C	65 °C	350 mA	0.99 K/W	671 cm ²
60 °C	65 °C	400 mA	0.83 K/W	805 cm ²
60 °C	65 °C	450 mA	0.71 K/W	945 cm ²

LLE G2 24x560mm 2400lm 8xx SNC

ta	tp	Forward current	R _{th, hs-a}	Cooling area
25 °C	65 °C	250 mA		self cooling
25 °C	65 °C	300 mA	4.93 K/W	135 cm ²
25 °C	65 °C	350 mA	4.02 K/W	166 cm ²
25 °C	65 °C	400 mA	3.35 K/W	199 cm ²
25 °C	65 °C	450 mA	2.84 K/W	234 cm ²
35 °C	65 °C	250 mA	4.66 K/W	143 cm ²
35 °C	65 °C	300 mA	3.69 K/W	181 cm ²
35 °C	65 °C	350 mA	3.01 K/W	221 cm ²
35 °C	65 °C	400 mA	2.51 K/W	265 cm ²
35 °C	65 °C	450 mA	2.13 K/W	313 cm ²
40 °C	65 °C	250 mA	3.88 K/W	172 cm ²
40 °C	65 °C	300 mA	3.08 K/W	217 cm ²
40 °C	65 °C	350 mA	2.51 K/W	265 cm ²
40 °C	65 °C	400 mA	2.09 K/W	318 cm ²
40 °C	65 °C	450 mA	1.78 K/W	375 cm ²
45 °C	65 °C	250 mA	3.10 K/W	215 cm ²
45 °C	65 °C	300 mA	2.46 K/W	271 cm ²
45 °C	65 °C	350 mA	2.01 K/W	332 cm ²
45 °C	65 °C	400 mA	1.68 K/W	398 cm ²
45 °C	65 °C	450 mA	1.42 K/W	469 cm ²
50 °C	65 °C	250 mA	2.33 K/W	286 cm ²
50 °C	65 °C	300 mA	1.84 K/W	361 cm ²
50 °C	65 °C	350 mA	1.51 K/W	443 cm ²
50 °C	65 °C	400 mA	1.26 K/W	531 cm ²
50 °C	65 °C	450 mA	1.06 K/W	626 cm ²
55 °C	65 °C	250 mA	1.55 K/W	430 cm ²
55 °C	65 °C	300 mA	1.23 K/W	543 cm ²
55 °C	65 °C	350 mA	1.00 K/W	665 cm ²
55 °C	65 °C	400 mA	0.84 K/W	798 cm ²
55 °C	65 °C	450 mA	0.71 K/W	941 cm ²
60 °C	65 °C	250 mA	0.77 K/W	862 cm ²
60 °C	65 °C	300 mA	0.61 K/W	1,088 cm ²
60 °C	65 °C	350 mA	0.50 K/W	1,334 cm ²
60 °C	65 °C	400 mA	0.42 K/W	1,602 cm ²
60 °C	65 °C	450 mA	0.35 K/W	1,891 cm ²

Notes

The actual cooling surface can differ because of the material, the structural shape, outside influences and the installation situation. Depending on the heat sink a heat conducting paste or heat conducting film might be necessary to keep the specified tp temperature.

3. Installation / wiring

3.1 Electrical supply/choice of LED Driver

LLE modules from Tridonic are not protected against overvoltages, overcurrents, overloads or short-circuit currents. Safe and reliable operation can only be guaranteed in conjunction with a LED Driver which complies with the relevant standards. The use of LED Driver from Tridonic in combination with LLE modules guarantees the necessary protection for safe and reliable operation.

If a LED Driver other than Tridonic is used, it must provide the following protection:

- Short-circuit protection
- Overload protection
- Overtemperature protection



LLE modules must be supplied by a constant current LED Driver. Operation with a constant voltage LED Driver will lead to an irreversible damage of the module.

Wrong polarity can damage the LLE.

With parallel wiring tolerance-related differences in output are possible (thermal stress of the module) and can cause differences in brightness. Not more than three LLE G2 24x560mm SNC or six LLE G2 24x280mm SNC are allowed to be connected in parallel. It is also recommended to use the functionality of the double terminal (internal loop through for parallel wiring) only for two LLE G2 24x560mm SNC or four LLE G2 24x280mm SNC (see wiring examples).

For parallel wiring only modules of the same forward voltage bin may be used.

The forward voltage bin indicated on the label of the module.

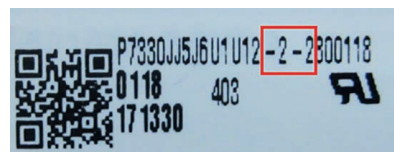

If a wire breaks or a complete module fails then the current passing through the other module increases. This may reduce its life considerably.

LLE can be operated either from SELV LED Drivers or from LED Drivers with LV output voltage.



LLE are basic isolated up to 335 V (if mounted with M4 screws with head diameter 7 mm in combination with plastic washers) against ground and can be mounted directly on earthed metal parts of the luminaire. If the max. output voltage of the LED Driver (also against earth) is above 335 V, an additional isolation between LED module and heat sink is required (for example by isolated thermal pads) or by a suitable luminaire construction.

At voltages > 60 V an additional protection against direct touch (test finger) to the light emitting side of the module has to be guaranteed. This is typically achieved by means of a non removable light distributor over the module.

3.2 Wiring

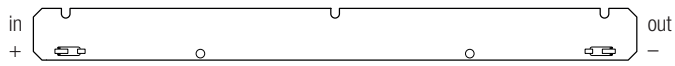

Wiring examples

Serial wiring:

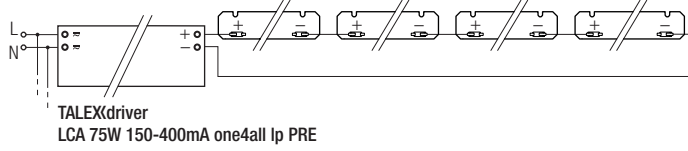

Parallel wiring:

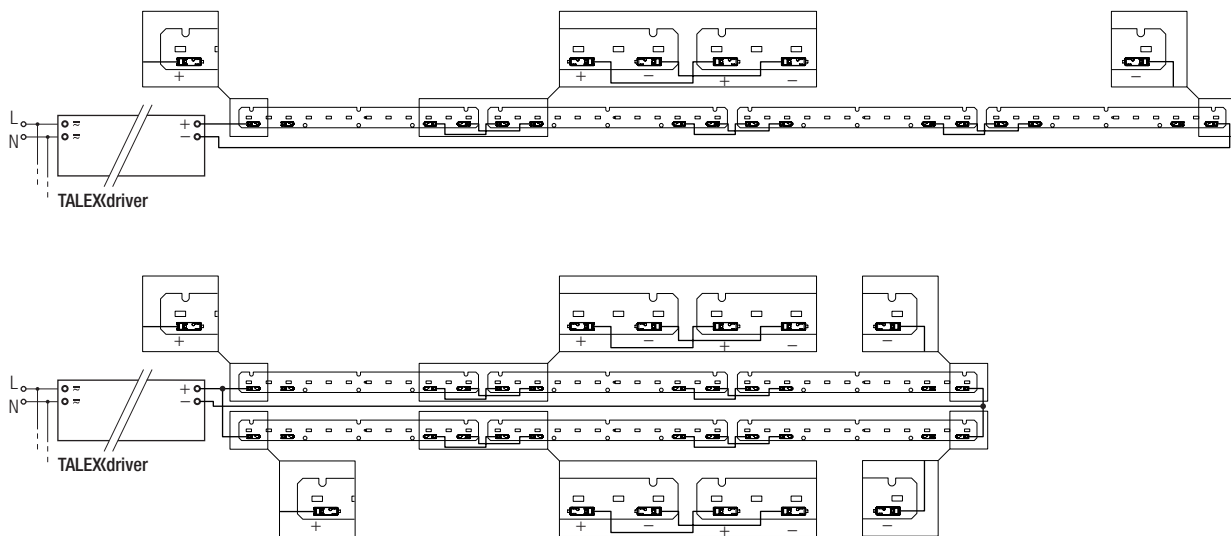

3.3 Wiring type and cross section

The wiring can be in stranded wires or solid with a cross section of 0.2 to 0.75 mm².

For the push-wire connection you have to strip the insulation (8–9 mm).

wire preparation:

0.2 – 0.75 mm²

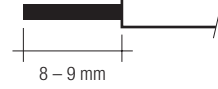

To remove the wires use a suitable tool (e.g. Microcon release pin) or through twist and pull.

3.4 Mounting instruction



None of the components of the LLE (substrate, LED, electronic components etc.) may be exposed to tensile or compressive stresses.

Max. torque for fixing: 0.5 Nm.

The LED modules are mounted onto a heat sink with min. 3 screws per module or ACL CLIP 4.3mm.



Chemical substance may harm the LED module. Chemical reactions could lead to colour shift, reduced luminous flux or a total failure of the module caused by corrosion of electrical connections.

Materials which are used in LED applications (e.g. sealings, adhesives) must not produce dissolver gas. They must not be condensation curing based, acetate curing based or contain sulfur, chlorine or phthalate.

Avoid corrosive atmosphere during usage and storage.

3.5 EOS/ESD safety guidelines



The device / module contains components that are sensitive to electrostatic discharge and may only be installed in the factory and on site if appropriate EOS/ESD protection measures have been taken. No special measures need be taken for devices/modules with enclosed casings (contact with the pc board not possible), just normal installation practice. Please note the requirements set out in the document EOS / ESD guidelines (Guideline_EOS_ESD.pdf) at: <http://www.tridonic.com/esd-protection>

4. Life-time

4.1 Life-time, lumen maintenance and failure rate

The light output of an LED Module decreases over the life-time, this is characterized with the L value.

L70 means that the LED module will give 70 % of its initial luminous flux. This value is always related to the number of operation hours and therefore defines the life-time of an LED module.

As the L value is a statistical value and the lumen maintenance may vary over the delivered LED modules.

The B value defines the amount of modules which are below the specific L value, e.g. L70B10 means 10 % of the LED modules are below 70 % of the initial luminous flux, respectively 90 % will be above 70 % of the initial value. In addition the percentage of failed modules (fatal failure) is characterized by the C value.

The F value is the combination of the B and C value. That means for F degradation and complete failures are considered, e.g. L70F10 means 10 % of the LED modules may fail or be below 70 % of the initial luminous flux.

Life-time declarations are informative and represent no warranty claim.

4.2 Lumen maintenance for LLE G2 24mm SNC

Forward current	tp temperature	L90 / F10	L90 / F50	L80 / F10	L80 / F50	L70 / F10	L70 / F50
		>50,000 h	>50,000 h	>50,000 h	>50,000 h	>50,000 h	>50,000 h
200 mA	45 °C	>50,000 h	>50,000 h	>50,000 h	>50,000 h	>50,000 h	>50,000 h
	55 °C	46,000 h	>50,000 h	>50,000 h	>50,000 h	>50,000 h	>50,000 h
	65 °C	35,000 h	>50,000 h	>50,000 h	>50,000 h	>50,000 h	>50,000 h
	75 °C	27,000 h	42,000 h	>50,000 h	>50,000 h	>50,000 h	>50,000 h
300 mA	85 °C	22,000 h	33,000 h	48,000 h	>50,000 h	>50,000 h	>50,000 h
	45 °C	27,000 h	42,000 h	50,000 h	>50,000 h	>50,000 h	>50,000 h
	55 °C	20,000 h	31,000 h	39,000 h	>50,000 h	>50,000 h	>50,000 h
	65 °C	16,000 h	24,000 h	31,000 h	47,000 h	47,000 h	>50,000 h
350 mA	75 °C	12,000 h	19,000 h	25,000 h	37,000 h	38,000 h	>50,000 h
	85 °C	10,000 h	15,000 h	20,000 h	30,000 h	31,000 h	46,000 h
	45 °C	20,000 h	31,000 h	36,000 h	>50,000 h	>50,000 h	>50,000 h
	55 °C	13,000 h	23,000 h	28,000 h	42,000 h	42,000 h	>50,000 h
500 mA	65 °C	12,000 h	18,000 h	22,000 h	33,000 h	34,000 h	50,000 h
	75 °C	9,000 h	14,000 h	18,000 h	27,000 h	27,000 h	41,000 h
	85 °C	7,000 h	11,000 h	14,000 h	22,000 h	22,000 h	33,000 h
	45 °C	10,000 h	15,000 h	17,000 h	25,000 h	25,000 h	36,000 h
500 mA	55 °C	7,000 h	11,000 h	13,000 h	19,000 h	19,000 h	29,000 h
	65 °C	6,000 h	9,000 h	10,000 h	15,000 h	16,000 h	23,000 h
	75 °C	4,000 h	7,000 h	8,000 h	12,000 h	13,000 h	19,000 h
85 °C	4,000 h	5,000 h	7,000 h	10,000 h	10,000 h	15,000 h	

4.3 Switching capability

50,000 cycles

Tested according to IEC 62717 Cl 10.3.3
30 s on / 30 s off at Imax

5. Electrical values

5.1 Declaration of electrical parameters

Irated ... Nominal operating current the module is designed for.

I_{max} ... Max. permissible continuous operating current incl. The tolerances of the LED driver.

Max. permissible LF current ripple ... Max. output current of the LED driver incl. Tolerances and LF current ripple must not exceed this value.

Max. permissible peak current ... The max. output peak current of the LED driver must not exceed this value.

5.2 Typ. forward voltage vs. forward current

LLE G2 24x280mm 1250lm 8xx SNC

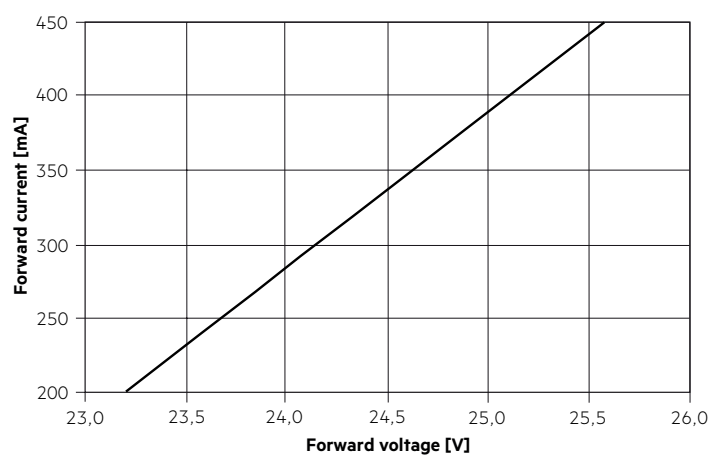

LLE G2 24x560mm 2400lm 8xx SNC

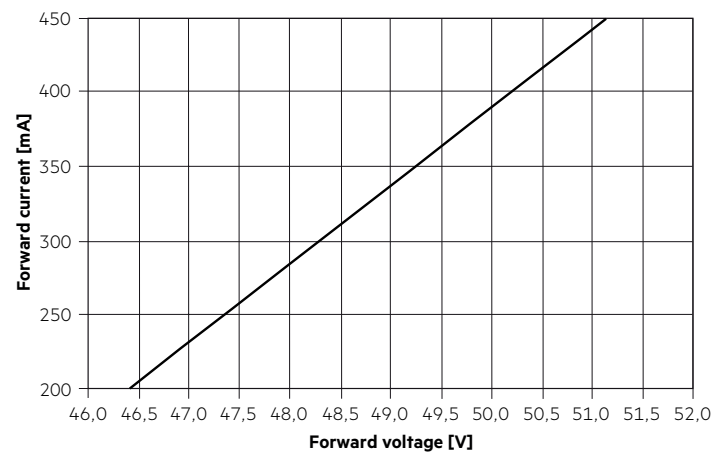

5.3 Forward voltage vs. tc temperature

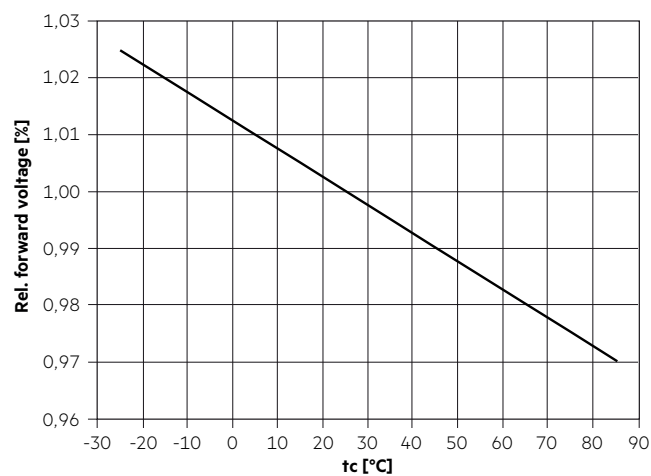

The diagrams are based on statistic values.
The real values can be different.

6. Photometric characteristics

6.1 Coordinates and tolerances according to CIE 1931

The specified colour coordinates are integral measured by current impulse of 300 mA and a duration of 100 ms.

The ambient temperature of the measurement is $t_a = 25^\circ\text{C}$.

The measurement tolerance of the colour coordinates are ± 0.01 .

3,000 K

	x0	y0
Centre	0.4353	0.4037

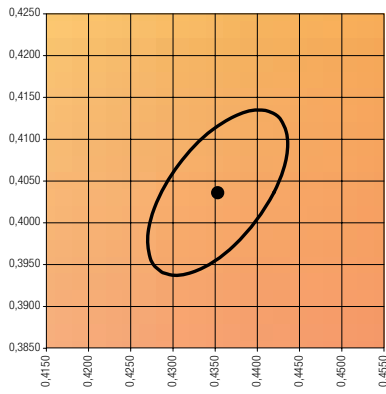

— MacAdam Ellipse: 4SDCM

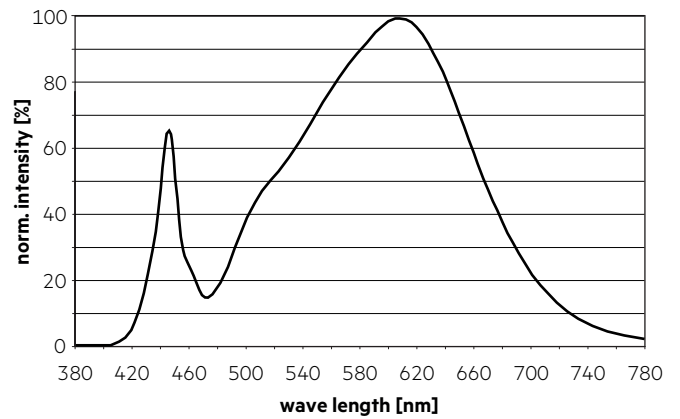

4,000 K

	x0	y0
Mittelpunkt	0.3832	0.3811

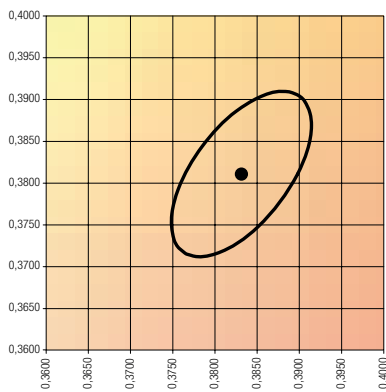

— MacAdam Ellipse: 4SDCM

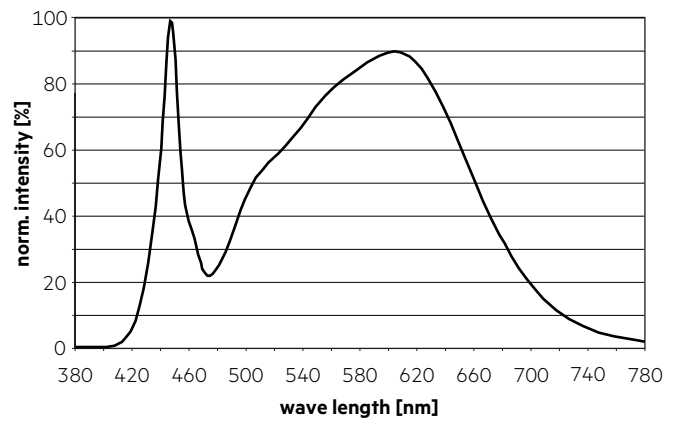

6,500 K

	x0	y0
Mittelpunkt	0.3136	0.3279

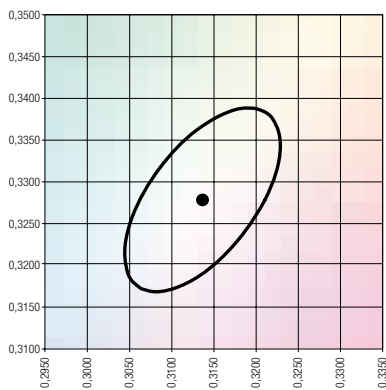

— MacAdam Ellipse: 4SDCM

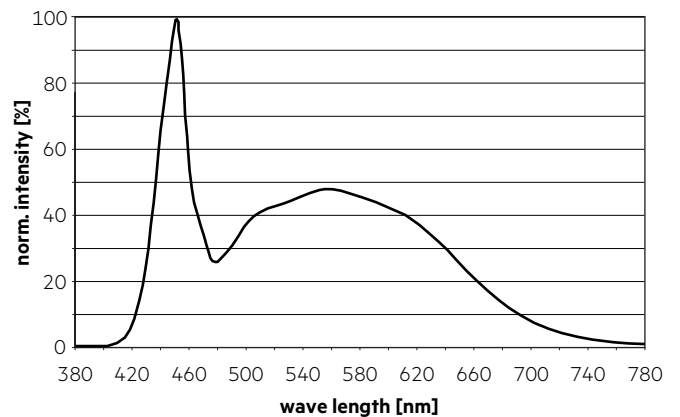

6.2 Light distribution

The optical design of the LLE product line ensures optimum homogeneity for the light distribution.

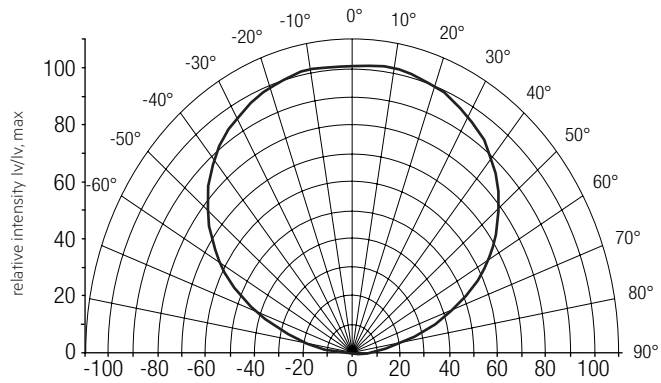

The colour temperature is measured integral over the complete module. The single LED light points can have deviations in the colour coordinates within MacAdam 3. To ensure an ideal mixture of colours and a homogenous light distribution a suitable optic (e. g. PMMA diffuser) and a sufficient spacing between module and optic (typ. 4 cm) should be used.

For further information see Design-in Guide, 3D data and photometric data on www.tridonic.com or on request.

6.3 Relative luminous flux vs. tc temperature

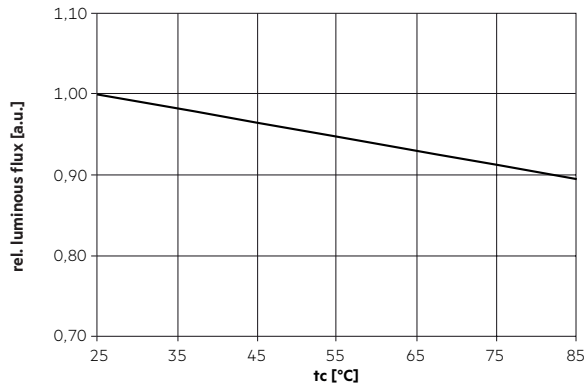

6.4 Relative luminous flux vs. operating current

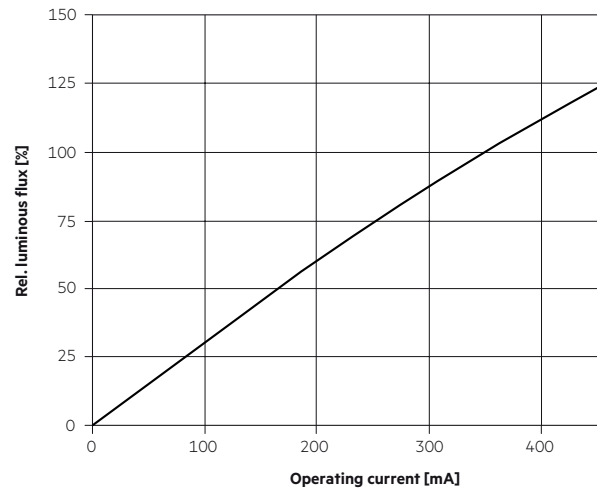

The diagrams are based on statistic values. The real values can be different.